

HANGING PLOT

No. 1 BARR BORDER	-8'-8"	7
BLUBOARD STORAGE	-8'-7"	6A
	-7'-5"	5A
	-6'-9"	5
	-5'-9"	4
No. 1 ELECTRIC HIGH	-4'-4"	3
No. 1 ELECTRIC LOW	-3'-9"	2
HARD BLACK LEERS	-2'-8"	1
YARN DRAPE	-1'-8"	A

NOTES
 ALL INSTRUMENTS ON 3'-0" CENTERS UNLESS OTHERWISE NOTED.
 DIMENSIONS ARE NOTED AND ARE LOCATED ON SUB-PLOT CONTOUR PLACEMENTS OF HANGERS AND FOLDERS.
 DIMENSIONS FOR HANGING PLOT FOR TRUSS ARE NOTED.
 ALL DIMENSIONS ARE IN FEET AND INCHES.
 ALL DIMENSIONS ARE TO FACE UNLESS NOTED OTHERWISE.

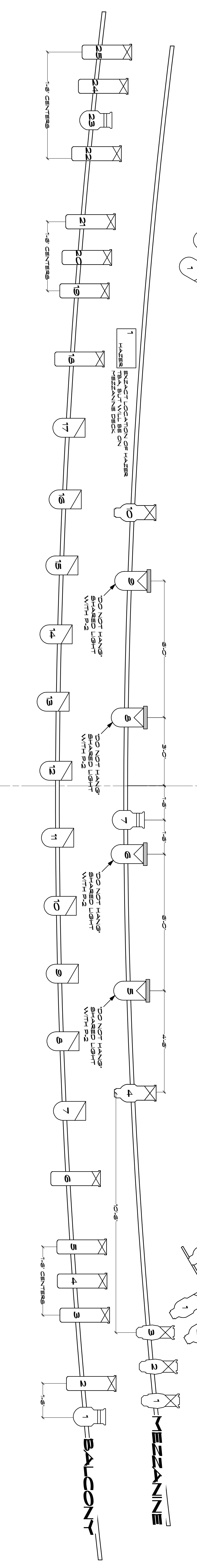

KEY

[Symbol]	SOURCE 4.36 575 W
[Symbol]	SOURCE 4.26 575 W
[Symbol]	SOURCE 4.19 575 W
[Symbol]	SX2 575 W
[Symbol]	SX3 575 W
[Symbol]	SX4 575 W
[Symbol]	ALTMAN K/W 12
[Symbol]	PAR 64 K/W
[Symbol]	PAR 64 W/L K/W
[Symbol]	PAR 64 HSP K/W
[Symbol]	PAR 64 V/L K/W
[Symbol]	PAR 18/8/B/8/E
[Symbol]	PANTOL
[Symbol]	STRE LIGHTS AS INDICATED ON PLOT

TYPICAL

[Symbol]	UNIT #
[Symbol]	GOBO
[Symbol]	4 RUNNER SCROLLER

MUDER OF CROWS
 BY MAC WELLMAN

THE HERBIE RESAUN THEATRE
 WINTER 2002

ART DIRECTOR: LUNA BUCKMAN
 LIGHTING DESIGNER: DANIEL SCHREIBER
 GENERAL MANAGER: JEFFREY BUCKMAN

SCALE: 1/8" = 1'-0"
 DATE: 1/28/02
 DRAWN BY: DGC
 OF 2